

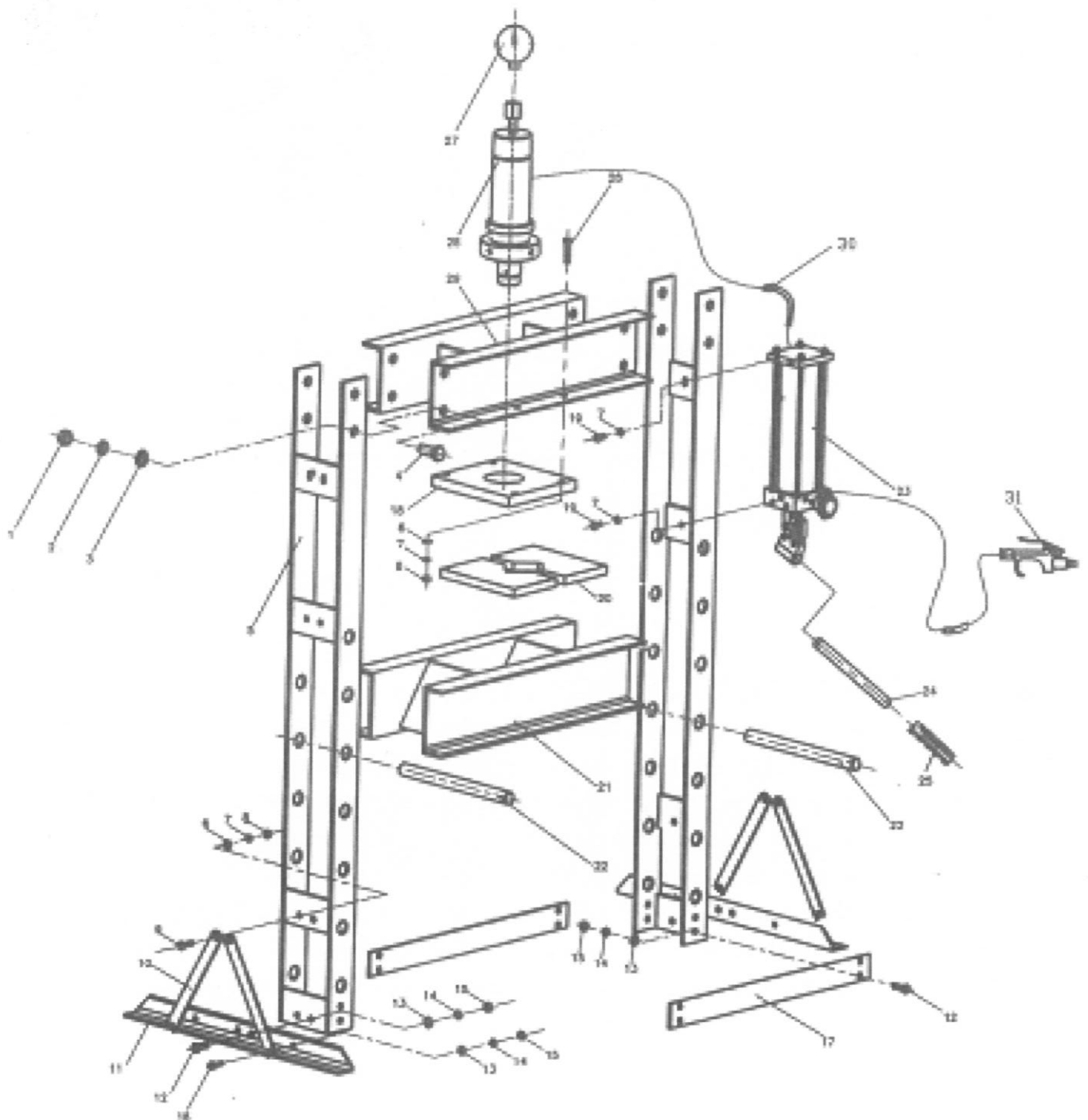

50 TON SHOP PRESS WITH GAUGE

OPERATING INSTRUCTIONS MANUAL

MODEL : SP50000G



SP50000G



50 TON SHOP PRESS WITH GAUGE

OPERATING INSTRUCTIONS MANUAL

MODEL : SP50000G

Item	Code	Description	Qty	Item	Code	Description	Qty
01		NUTS M20	8	17		BOARD ACROSS	2
02		SPRING WASHER M12	8	18		SETTLED BASE	1
03		WASHER M12	8	19		NUTS BOLT M10X25	4
04		NUT BOLT M20X45	8	20		ARBOR PLATE	2
05		SIDE FRAME ASSEMBLY	2	21		MIDDLE GIRDER	1
06		WASHER M10	8	22		SUPPORT PINS	2
07		SPRING M10	12	23		PRESS PUMP	1
08		NUTS M10	12	24		HANDLE	1
09		NUTS BOLT M10X30	4	25		HANDLE GRIP	1
10		ARM SUPPORT	4	26		NUTS BOLT M10X50	4
11		BASE SUPPORTS	2	27		PRESSURE GAUGE	1
12		NUTS BOLT M12X30	12	28		PRESS CYLINDER	1
13		WASHER M12	16	29		ACROSS GIRDER	1
14		SPRING M12	16	30		VALVE	1
15		NUTS M12	16	31		HYDUALIC HOSE	1
16		NUT BOLT M12X25	4		TRTTN50TSP	TIGHTENER	
					TRTTNWC50TSP	TIGHTENER W/O PLASTIC COVER	



50 TON SHOP PRESS WITH GAUGE

OPERATING INSTRUCTIONS MANUAL

MODEL : SP50000G

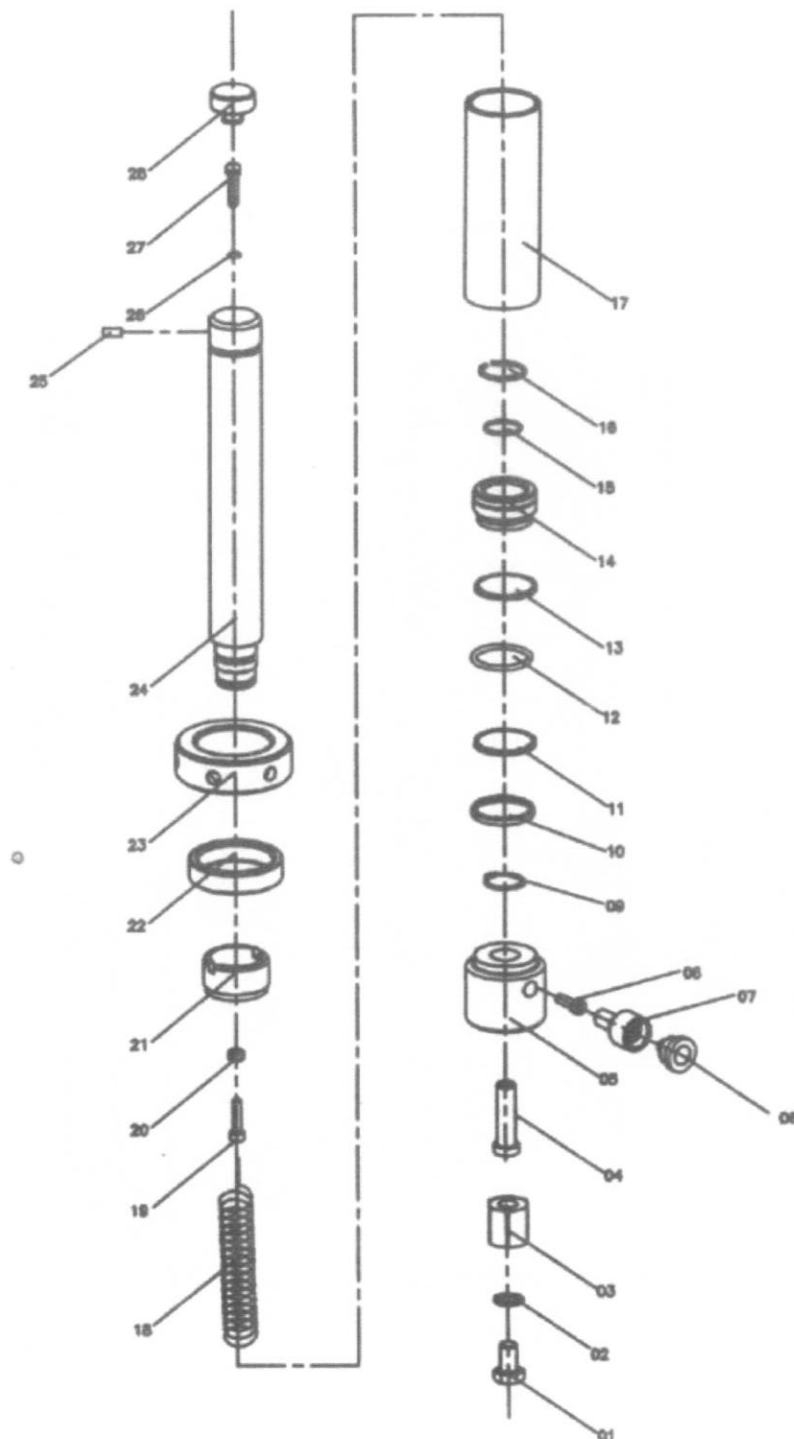



50 TON SHOP PRESS WITH GAUGE

OPERATING INSTRUCTIONS MANUAL

MODEL : SP50000G

Item	Description	Qty	Item	Description	Qty
01	BOLT	1	15	'O' – RING 40X2.65	1
02	RECTANGULAR RING	1	16	SPACING RING	1
03	RETAINER NUT	1	17	CYLINDER	1
04	TIE-IN	1	18	SPRING	1
05	SEAT OF CYLINDER	1	19	BOLT M8X50	1
06	DUST CAP	1	20	NUT M8	1
07	COUPLING BOLT	1	21	RETAINER NUT	1
08	BOLT M6X35	1	22	PROTECTING RING	1
09	SNAP RING	1	23	PROTECTING RING	1
10	“Y”-RING	1	24	PISTON ROD	1
11	BACK RING	1	25	BOLT M8X10	1
12	'O' – RING 70X2.65	1	26	RECTANGGULAR RING	1
13	NYLON RING	1	27	BOLT M8X10	1
14	PISTON RING	1	28	TOP NUT	1